

p.c.b. layout

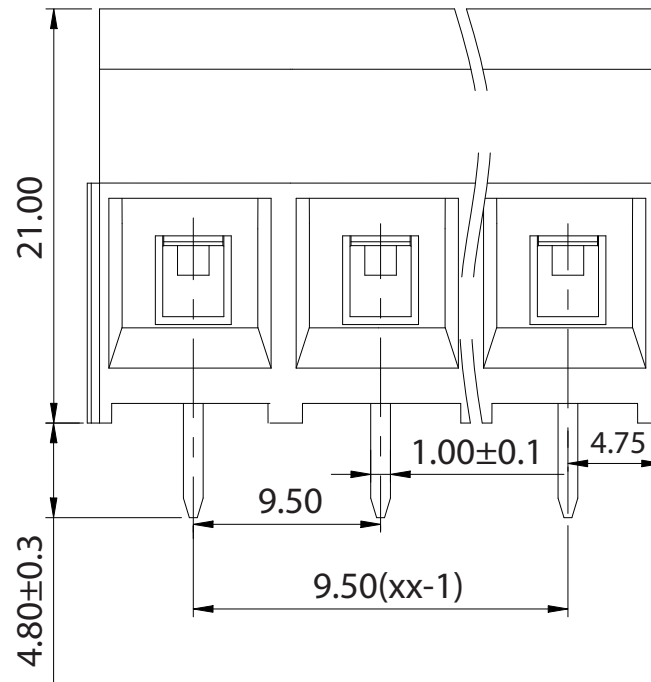

Approvals

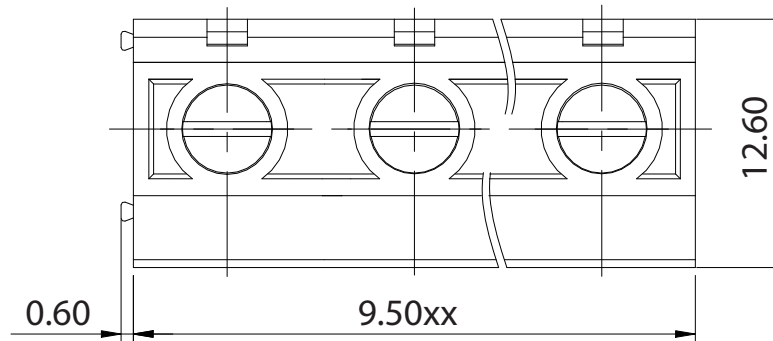

30A-300V

Electrical

Rated voltage IEC	630V
Rated current IEC	32A
Contact resistance	20mΩ
Insulation resistance	500MΩ/DC500V
Withstanding voltage	AC2000V/1 min
Wire range	26-10AWG - 4 mm2
Torque	0,5Nm(4.43 Lb.In)
Temp. Range	-40°C + 105°C
Stripping length	6mm
Max sold. time	+250°C for 5sec

Dimensions

Pitch	9,5 mm
Poles	2÷24

Material

Housing	PA66UL94V0
Pin	Copper alloy, tin plated
Cage	Copper alloy, Ni plated
Screws	M3, Steel Zn plated
Side Block	
Nut screw	
Clamp	

General description of ordering code

Series	n. Poles	Pitch	Version	Color	Custom
MRS94	2÷24	-9.5	-V		

Version Date

01/26 30/01/26



euro-block



UNITS: mm

SHEET SIZE: ISO A4

SCALE: 10:1

> 0 ~ 3

> 3 ~ 18

> 18 ~ 50

> 50 ~ 120

± 0.12

± 0.15

± 0.3

± 0.5



First angle projection

MRS94-9.5-V