

p.c.b layout

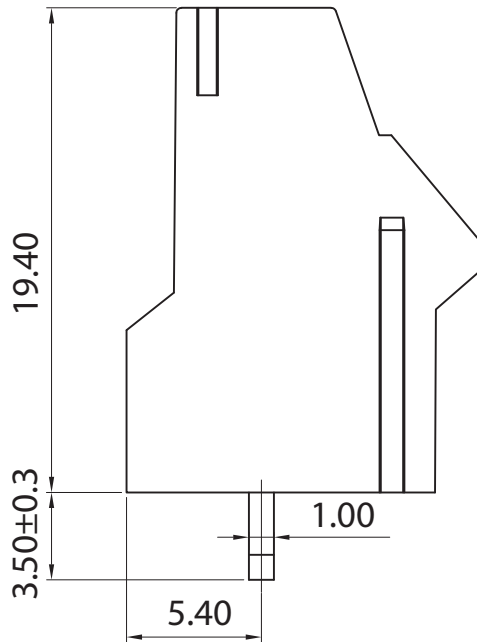

Approvals

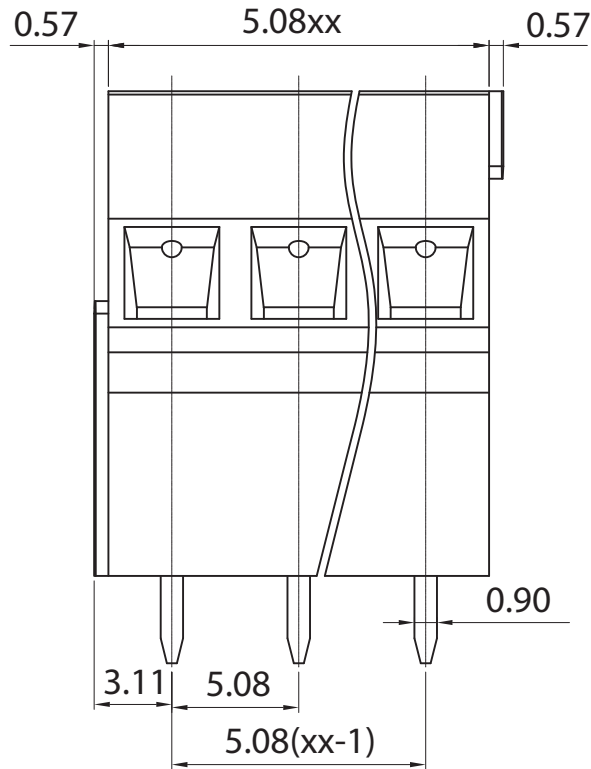
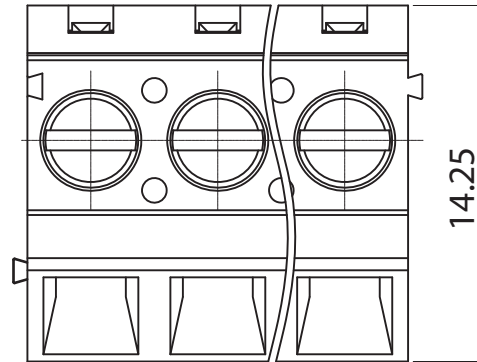

Electrical

Rated voltage	250V
Rated current	20A
Contact resistance	20mΩ
Insulation resistance	500MΩ/DC500V
Withstanding voltage	AC2000V/1 min
Wire range	2,5mm ² 22÷12 AWG
Torque	0,4Nm(3.6Lb In)
Temp. Range	-40°C + 105°C
Stripping length	10 mm.
Max sold. time	+250°C for 5 sec.

Dimensions

Pitch	5,08 mm
Poles	2÷24

Material

Housing	PA66 UL94V0
Pin	Copper Alloy, Sn plated
Cage	Copper Alloy, Ni plated
Screws	M3; Steel Zn plated
Side Block	
Nut screw	
Clamp	

General description of ordering code

Series	n. Poles	Pitch	Version	Color	Custom
DRI52	2÷24	-5,08	-V		

Version Date

01/22 28/01/2022



euro-block



UNITS: mm

SHEET SIZE: ISO A4

SCALE: 3:1

> 0 ~ 3

> 3 ~ 18

> 18 ~ 50

> 50 ~ 120

± 0.12

± 0.15

± 0.3

± 0.5



First angle projec on

DRI52-5.08-V