

Approvals



Electrical

Rated voltage 200V  
 Rated current 10A  
 Contact resistance 20mΩ  
 Insulation resistance 500MΩ/DC500V  
 Withstanding voltage AC1600V/1min  
 Wire range 26-12 AWG 1,5mm2

Torque  
 Temp. Range -40°C +105°C  
 Stripping length 4 mm  
 Max sold. time +250°C for 5 sec

Dimensions

Pitch 3,81 mm  
 Poles 2÷24

Material

Housing PA66 UL94V0  
 Pin Copper Alloy, Sn plated  
 Cage Copper Alloy, Ni plated  
 Screws M2 steel, Zn plated  
 Side Block  
 Nut screw  
 Clamp

General description of ordering code

Series	n. Poles	Pitch	Version	Color	Custom
SRI31	02÷24	-3.81	-A4		

Version Date

01/22 17/03/22

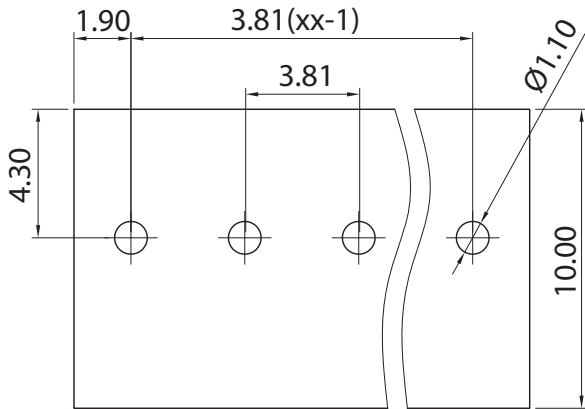

p.c.b. layout

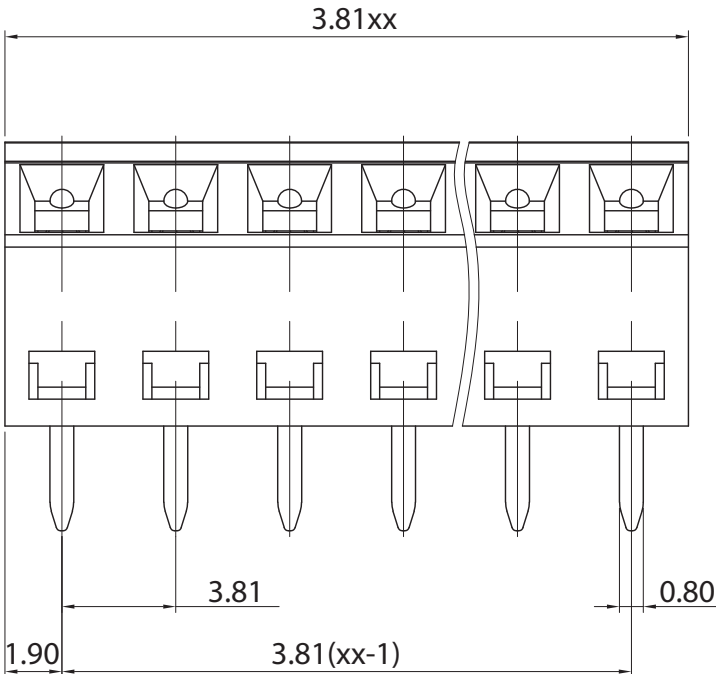
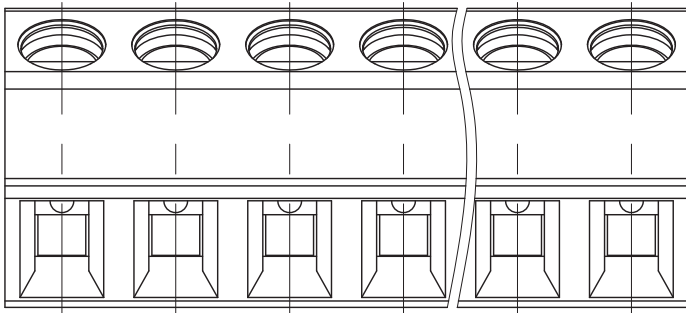
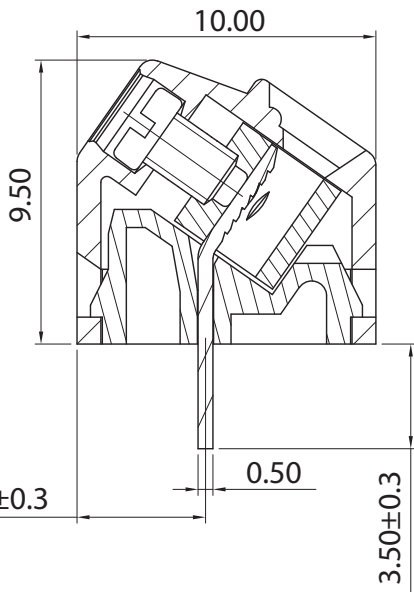

euro-block



linear dimension (Tolerances Standard GB/T 14486-2008)										UNITS: mm			
variable range	to 6	over 6 to 10	over 10 to 30	over 30 to 60	over 60 to 100	over 100 to 160	over 160 to	to 10	over 10 to 100	over 100 to	SCALE: 10:1		
tolerance	±0.20	±0.30	±0.50	±0.70	±1.00	±1.30	±1.60	0.10	0.30	0.60	SHEET SIZE: ISO A4		

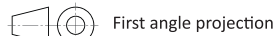

SRI31-3.81-A4