

p.c.b. layout

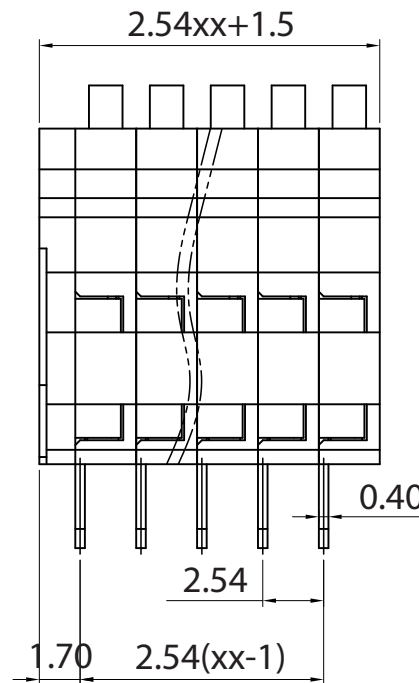

Approvals

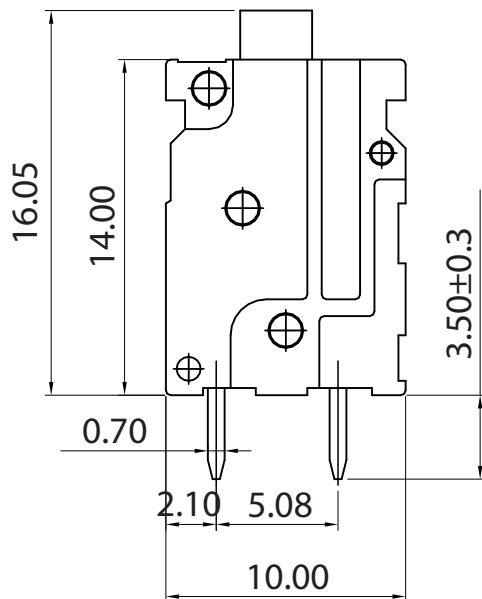
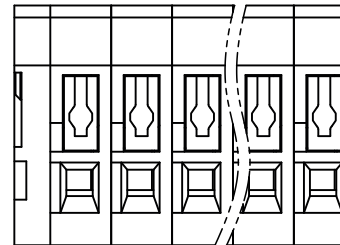

5A-300V

Electrical

Rated voltage	160V
Rated current	6 A
Contact resistance	20 mΩ
Insulation resistance	500 MΩ/DC 500 V
Withstanding voltage	AC 1300 V/1 min
Wire range	0,5 mm ² 26÷18 AWG

Torque	
Temp. Range	-40°C + 105°C
Stripping length	10 mm
Max sold. time	+250°C for 5 sec.

Dimensions

Pitch	2.54 mm
Poles	1÷xx

Material

Housing	PA66 UL94V0
Pin	
Cage	Copper Alloy, Sn plated
Screws	
Side Block	
Nut screw	
Clamp	

General description of ordering code

Series	n. Poles	Pitch	Version	Color	Custom
MRM8	1÷xx	-2.54	-V		

Version Date

01/23 10/03/23



euro-block



UNITS: mm

SHEET SIZE: ISO A4

SCALE: 3:1

> 0 ~ 3

> 3 ~ 18

> 18 ~ 50

> 50 ~ 120

± 0.12

± 0.15

± 0.3

± 0.5



First angle projection

MRM8-2.54-V