

p.c.b. layout

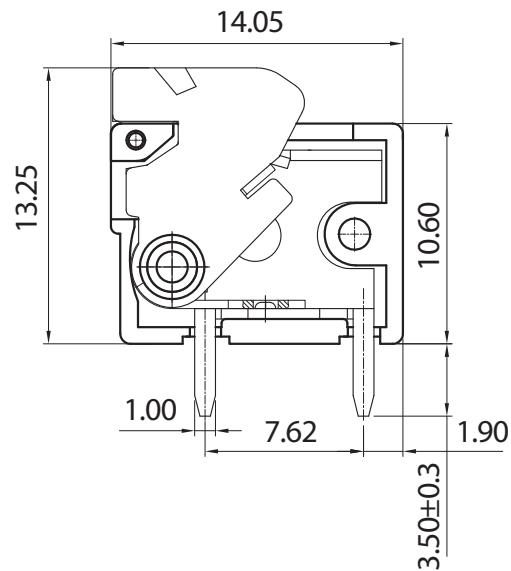

Approvals

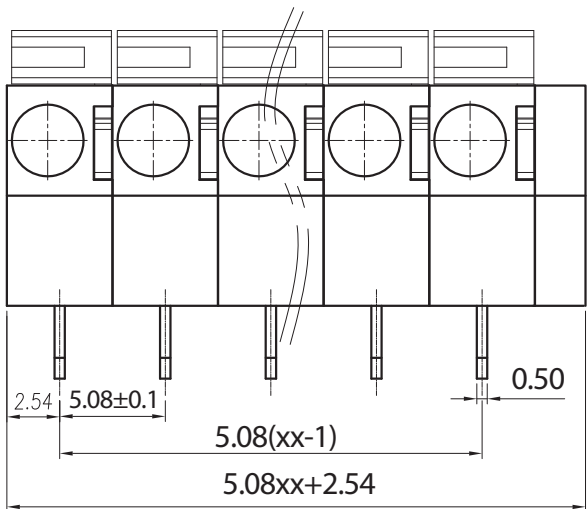

Electrical

Rated voltage	250 V
Rated current	15 A
Contact resistance	20 mΩ
Insulation resistance	500 MΩ/DC 500 V
Withstanding voltage	AC 2000 V/1 min
Wire range	1 mm ² 26÷16 AWG

Torque	---
Temp. Range	-40°C + 105°C
Stripping length	9 mm
Max sold. time	+250°C for 5 sec.

Dimensions

Pitch	5,08 mm
Poles	1÷xx

Material

Housing	PA66 UL94V0
Pin	Copper Alloy, Sn plated
Cage	Stainless Steel
Screws	---
Side Block	---
Nut screw	---
Clamp	---

General description of ordering code

Series	n. Poles	Pitch	Version	Color	Custom
MRM7	1÷xx	-5.08	-H		

Version Date

19/01	22/07/19
-------	----------



euro-block



UNITS: mm

SHEET SIZE: ISO A4

SCALE: 3:1

> 0 ~ 3

> 3 ~ 18

> 18 ~ 50

> 50 ~ 120

± 0.12

± 0.15

± 0.3

± 0.5



First angle projection

MRM7-5.08-H