

Approvals

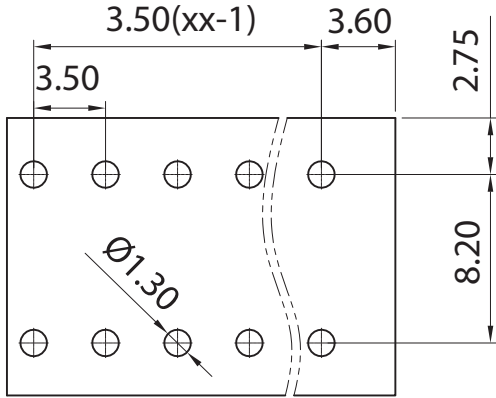

p.c.b. layout

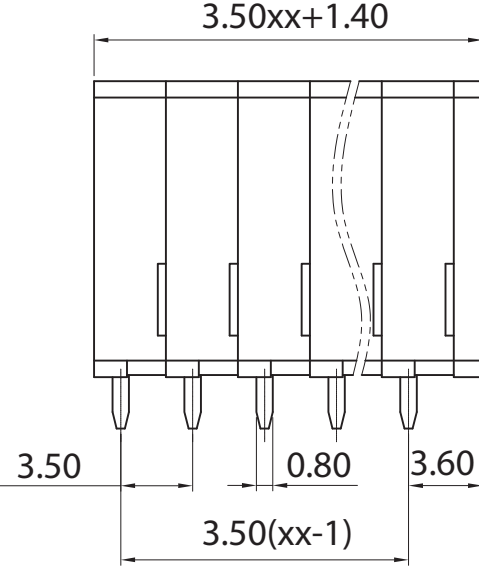
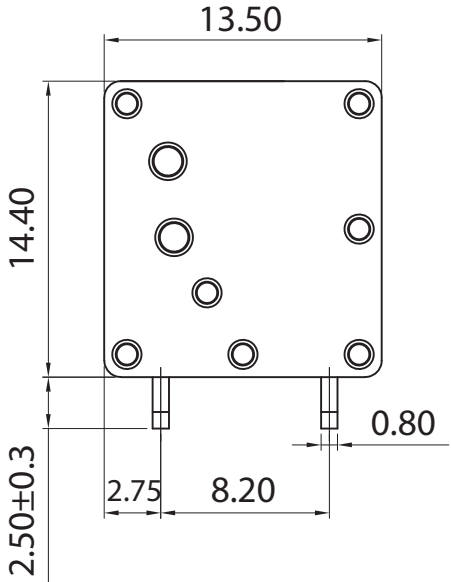
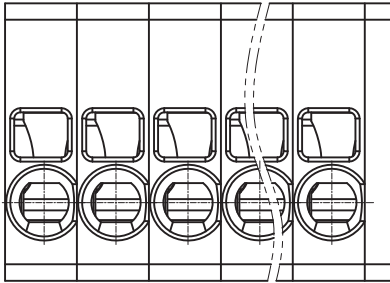

Electrical

Rated voltage	160 V
Rated current	17,5 A
Contact resistance	20 mΩ
Insulation resistance	500 MΩ/DC 500 V
Withstanding voltage	AC 1600 V/1 min
Wire range	1,5 mm ² 24÷16 AWG
Torque	---
Temp. Range	-40°C + 105°C
Stripping length	11 mm
Max sold. time	+250°C for 5 sec.

Dimensions

Pitch	3.5 mm
Poles	1÷30

Material

Housing	PA66 UL94V0
Pin	
Cage	Copper Alloy, Sn plated
Screws	
Side Block	
Nut screw	
Clamp	

General description of ordering code

Series	n. Poles	Pitch	Version	Color	Custom
MFM3	1÷30	-3.5	-V		

Version Date

01/22 10/06/2022



euro-block



UNITS: mm

SHEET SIZE: ISO A4

SCALE: 3:1

> 0 ~ 3	> 3 ~ 18	> 18 ~ 50	> 50 ~ 120
± 0.12	± 0.15	± 0.3	± 0.5

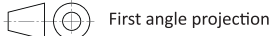

MFM3-3.5-V