

p.c.b. layout

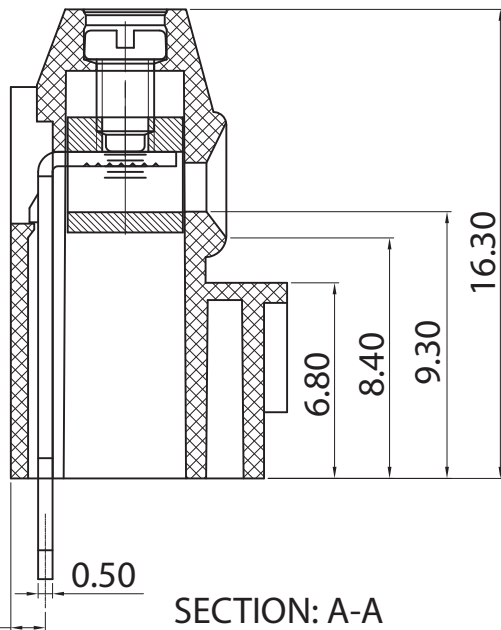

SECTION: A-A

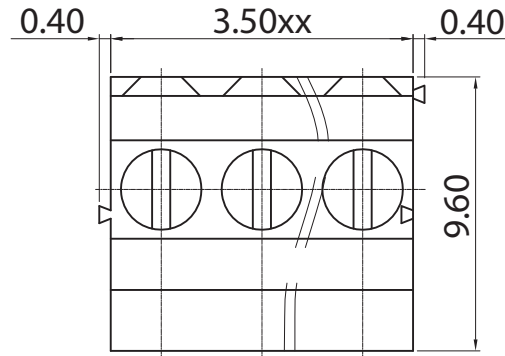
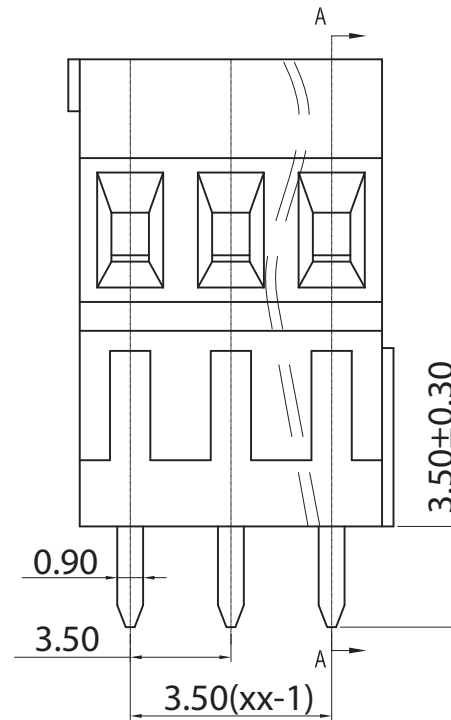

Approvals



15A-300V
13,5A-160V

Electrical

Rated voltage 250V
 Rated current 15A
 Contact resistance 20mΩ
 Insulation resistance 500MΩ/DC500V
 Withstanding voltage AC 1600V/1 min
 Wire range 28÷16 AWG 1 mm²
 Torque 0,2Nm(1.8Lb in)
 Temp. Range -40°C+105°C
 Stripping length 6mm
 Max sold. time +250°C for 5 sec.

Dimensions

Pitch 3,50 mm
 Poles 2÷24

Material

Housing PA66 UL94V0
 Pin Copper Alloy, tin plated
 Cage Copper Alloy, NI plated
 Screws M2, Steel Zn plated
 Side Block
 Nut screw
 Clamp

General description of ordering code

Series	n. Poles	Pitch	Version	Color	Custom
MRH31	2÷24	-3.50	-V		

Version	Date
01/26	11/03/26



euro-block



UNITS: mm

SHEET SIZE: ISO A4

SCALE: 10:1

> 0 ~ 3

> 3 ~ 18

> 18 ~ 50

> 50 ~ 120

± 0.12

± 0.15

± 0.3

± 0.5

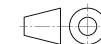

First angle projection

MRH31-3.5-V