

p.c.b. layout

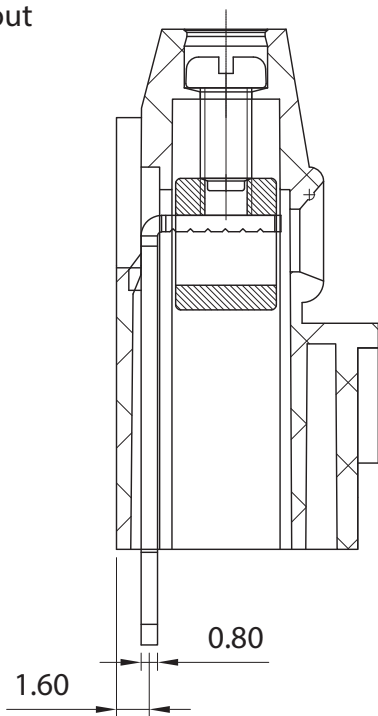

SECTION A-A

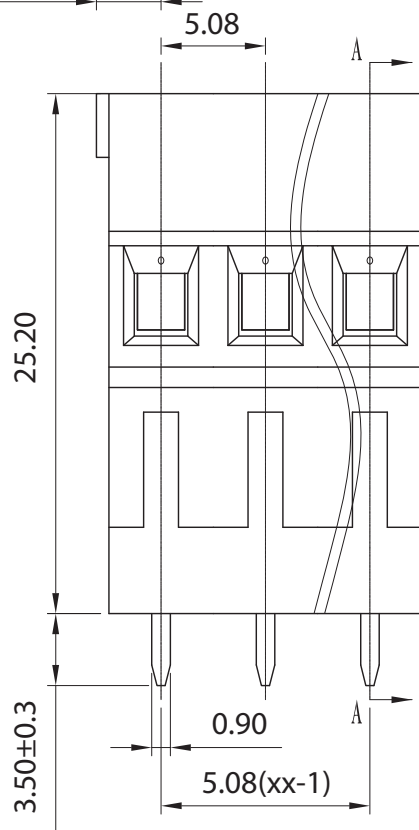
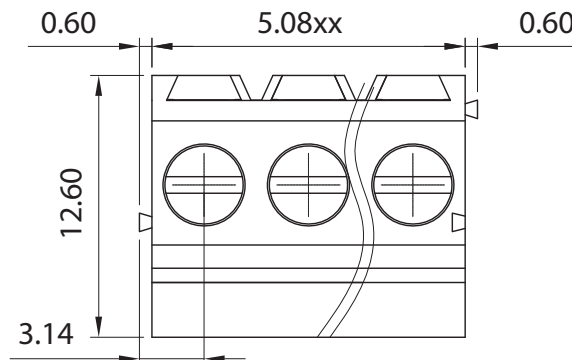

Approvals



15A-300V

Electrical

Rated voltage 250V
 Rated current 18A
 Contact resistance 20mΩ
 Insulation resistance 500MΩ/DC500V
 Withstanding voltage AC1600V/1min
 Wire range 30-14 AWG 2,5mm²

Torque 0,4Nm (3.6Lb in)
 Temp. Range -40°C +105°C
 Stripping length 7 mm
 Max sold. time +250°C for 5 sec

Dimensions

Pitch 5,08 mm
 Poles 2÷24

Material

Housing PA66 UL94V0
 Pin Copper Alloy, Sn plated
 Cage Copper Alloy, Ni plated
 Screws M2.5 steel, Zn plated
 Side Block
 Nut screw
 Clamp

General description of ordering code

Series	n. Poles	Pitch	Version	Color	Custom
MHH52	2÷24	-5.08	-V		

Version Date

01/2020 30/05/2020



euro-block



linear dimension (Tolerances Standard GB/T 14486-2008)								UNITS: mm			
variable range	to 6	over 6 to 10	over 10 to 30	over 30 to 60	over 60 to 100	over 100 to 160	over 160 to	to 10	over 10 to 100	over 100 to	SCALE: 10:1
tolerance	±0.20	±0.30	±0.50	±0.70	±1.00	±1.30	±1.60	0.10	0.30	0.60	SHEET SIZE: ISO A4

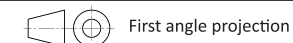

MHH52-5.08-V